

O & M Manual - Fume Hoods

Recommendations for the proper
operation and maintenance of

BMC

Laboratory Fume Hoods

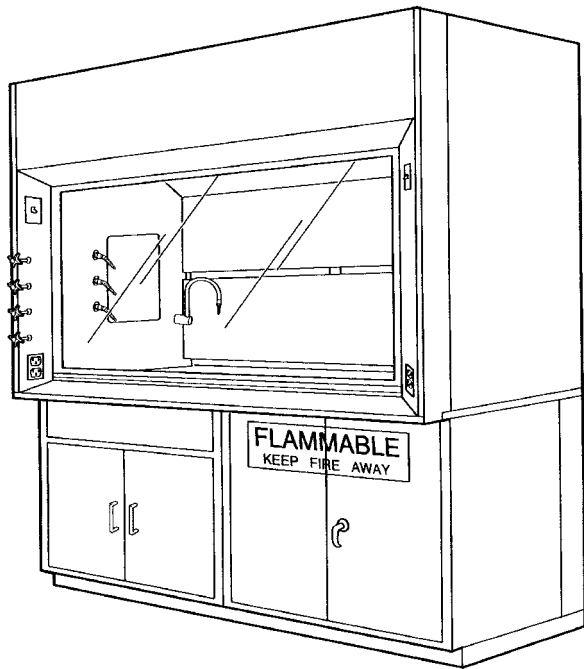

Represented by:

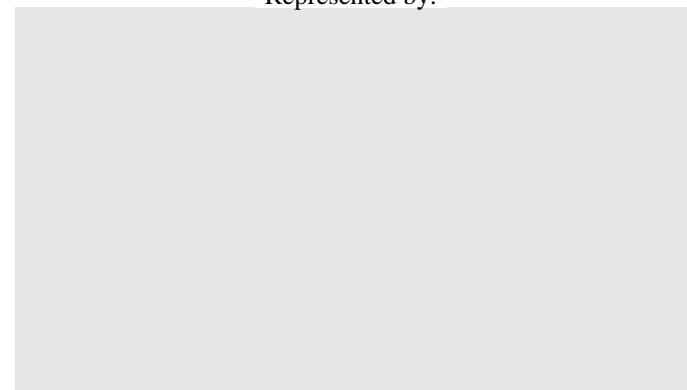

BMC, P.O. Box 4089, Muskegon, MI 49444 (616)-733-1206

OPERATION RECOMMENDATIONS

USE

- 1.1 Limit laboratory fume hood use to those activities for which the unit is designed. Alternative devices, such as safety cabinets or glove boxes, should be used when appropriate.
- 1.2 Only specially designed laboratory fume hoods should be used for perchloric acid work. This fume hood type should be labeled and its use should be limited to perchloric acid procedures.
- 1.3 Use of laboratory fume hoods as storage enclosures for corrosive, toxic, or flammable materials may jeopardize fume hood performance and create unnecessary hazards. Limit materials within the hood to those required for immediate use.

GENERAL OPERATIONS

- 2.1 Turn on interior light for proper illumination of work area.
- 2.2 Verify that exhaust system is operating properly and that air is entering and flowing through the fume hood before starting fume producing activities.
- 2.3 Safe and proper fume hood operation requires an understanding of the function of fume hood baffles and various baffle settings. Different fume hood designs require variations in baffle settings. Operators must adhere to fume hood manufacturer's instruction relative to baffle position for safe and efficient function.
- 2.4 Set-ups and apparatus should be as far back from the fume hood face as possible for safety and optimum performance. A set back of six inches is necessary for proper fume hood operation. Avoid blocking baffle openings.
- 2.5 Large bulky objects should not be placed directly on fume hood working surface. Block up two or three inches to allow a flow of air under the object and into lower rear baffle exhaust opening.
- 2.6 Avoid rapid movement and excessive personnel passage in front of the fume hood. Air disturbances created may draw fumes out of the hood.
- 2.7 The laboratory fume hood sash is designed to be used as a safety shield. Move vertical type sash to lowest position that provides proper access and carry out manipulations with sash protecting head and upper body. When feasible, use horizontal sliding sash as a face and body shield.
- 2.8 As a safety precaution, avoid placing head inside of the laboratory fume hood.
- 2.9 On fume hoods without a bypass, avoid closing sash completely when the blower is on and the fume hood is in use.
- 2.10 Laboratory fume hood sash should be kept closed when the exhaust system is turned off and the hood is not in use.
- 2.11 Never permit the temperature of inside sash surface to reach or exceed 160° F., unless the sash material is the heat resistant type.

OPERATION OF PERCHLORIC ACID FUME HOODS

Caution: Only personnel fully cognizant with the properties of perchloric acid and the hazards associated with it should perform perchloric acid procedures.

- 3.1 Use only specifically designed laboratory fume hoods for perchloric acid. This type of fume hood should be so labeled and not used as a general purpose laboratory fume hood. Miscellaneous work should not be performed in perchloric acid fume hoods because of extreme hazards.
- 3.2 Follow all operations of general purpose laboratory fume hoods (Section 2.1 through 2.11).
- 3.3 Safety requires regular water wash down of fume hood interior, duct work, and blower after use or preferably after each experiment.
- 3.4 Remove baffle(s) for access to all surfaces and follow wash down procedures with detailed inspection. Flush away any deposits.
- 3.5 Utilize smallest quantities of perchloric acid to fit procedural requirements.
- 3.6 Spark producing apparatus should not be used inside a perchloric acid fume hood.
- 3.7 All apparatus used within the hood interior should have inorganic coatings and lubricants.

INSPECTION AND MAINTENANCE

INSPECTION

- 4.1 Safety considerations require that a schedule of inspection and documentation be set up for every laboratory fume hood at least annually.
- 4.2 An inspection record should be maintained. This record may be in the form of a label attached to the hood, or a log held by the laboratory director or health safety director.
- 4.3 Inspection procedures should include instrument verification of fume hood face velocity and a determination of usage by observation and interview.
- 4.4 Inspection procedures should consist of a physical examination of liner condition and cleanliness, baffle and sash operation and condition, counter balance cables, light operation and condition, and service fixture function.
- 4.5 Inspection results should be recorded and reported to the proper authority for any required action.

Note: Special purpose fume hoods such as those used with radioactive materials or perchloric acid require additional inspection procedures to cover special equipment and requirements.
- 4.6 Options, such as low air flow detectors, when installed, should be inspected at least annually. Where extremely hazardous or corrosive conditions exist or when filters are present in the system, the inspection frequency should be increased appropriately. Velocity and pressure sensing detectors should be tested at each inspection. Low-flow or no-flow alarms of the visible (lights) or audible (horns or bells) type should be tested for correct operation at least at each inspection. Signal transmission for alarms designed to activate signals at more than one location should be verified at each location during each inspection. When air flow detectors are not provided, or measured air flow tests are not made quarterly, fan belts should be inspected quarterly. Frayed or broken belts should be replaced promptly. Where double pulleys and belts are employed, the inspection frequency may be semi-annually.

MAINTENANCE

- 5.1 Fume hood maintenance procedures consist primarily of clean up, adjustment, and replacement of worn, damaged or non-functioning parts. Use good housekeeping in laboratory fume hoods at all times. Periodically clean sash, exterior and interior surface, including fluorescent light panel. Replace fluorescent lamps periodically to maintain adequate illumination.

- 5.2 Clean-up should be accomplished by, or under the supervision of, a knowledgeable laboratory safety officer and should include removal of the baffle for clean-up of all interior surfaces.
- 5.3 Lubrication of sash guides, cables, pulley wheels, and other working parts is not required.
- 5.4 Replace broken, worn, or non-functioning parts as required.
- 5.5 Flush all spills immediately using neutralizing compounds as required and clean thoroughly.

Note: Special parts, options, and accessories should be maintained as required.